

Impacts of New Technology on Rhode Island's 911 System

A Report to the Joint Municipal Shared
Services Study Commission

ASERA Division
Taubman Center for Public Policy & American Institutions
Brown University
September 16, 2014

Charge from Commission

- Comprehensive examination of the current 911 system and the impacts of new technology with regard to:
 - Public safety
 - Cost implications

Summary

- RI's Current System: E-911
- Coming Technology: NG-911
- Opportunities and Challenges of NG-911
- Alternative Structures for NG-911
 - Horizontal Consolidation
 - Vertical Consolidation
- Recommendations

E-911

- One Primary Public Safety Answering Point (PSAP)– North Scituate
 - All 911 calls received by North Scituate
- Voice calls only
 - Almost all information relayed verbally
 - After determining the nature and location of the call, telecommunicators transfer the call to the appropriate dispatch center(s)
- 72 Local Dispatch Centers
 - Local dispatchers send appropriate first responders

Figure 1: Current 911 System

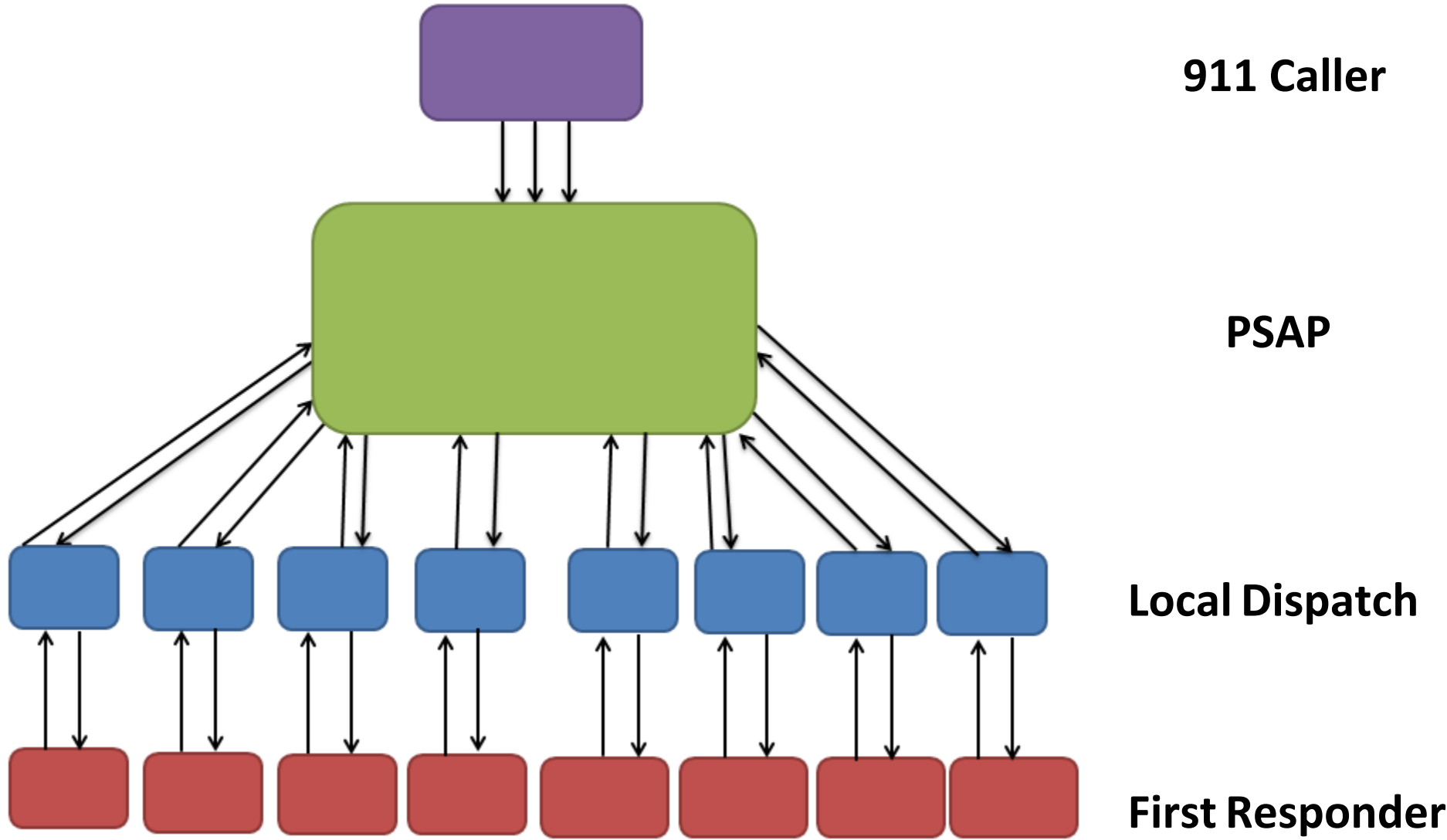

NG-911

- Texts, video, pictures, other multimedia
- NG-911 is coming to Rhode Island
 - North Scituate to receive texts messages in early 2015
- The state needs a cohesive plan for implementing NG-911 throughout the 911 system

Figure 1: Current 911 System

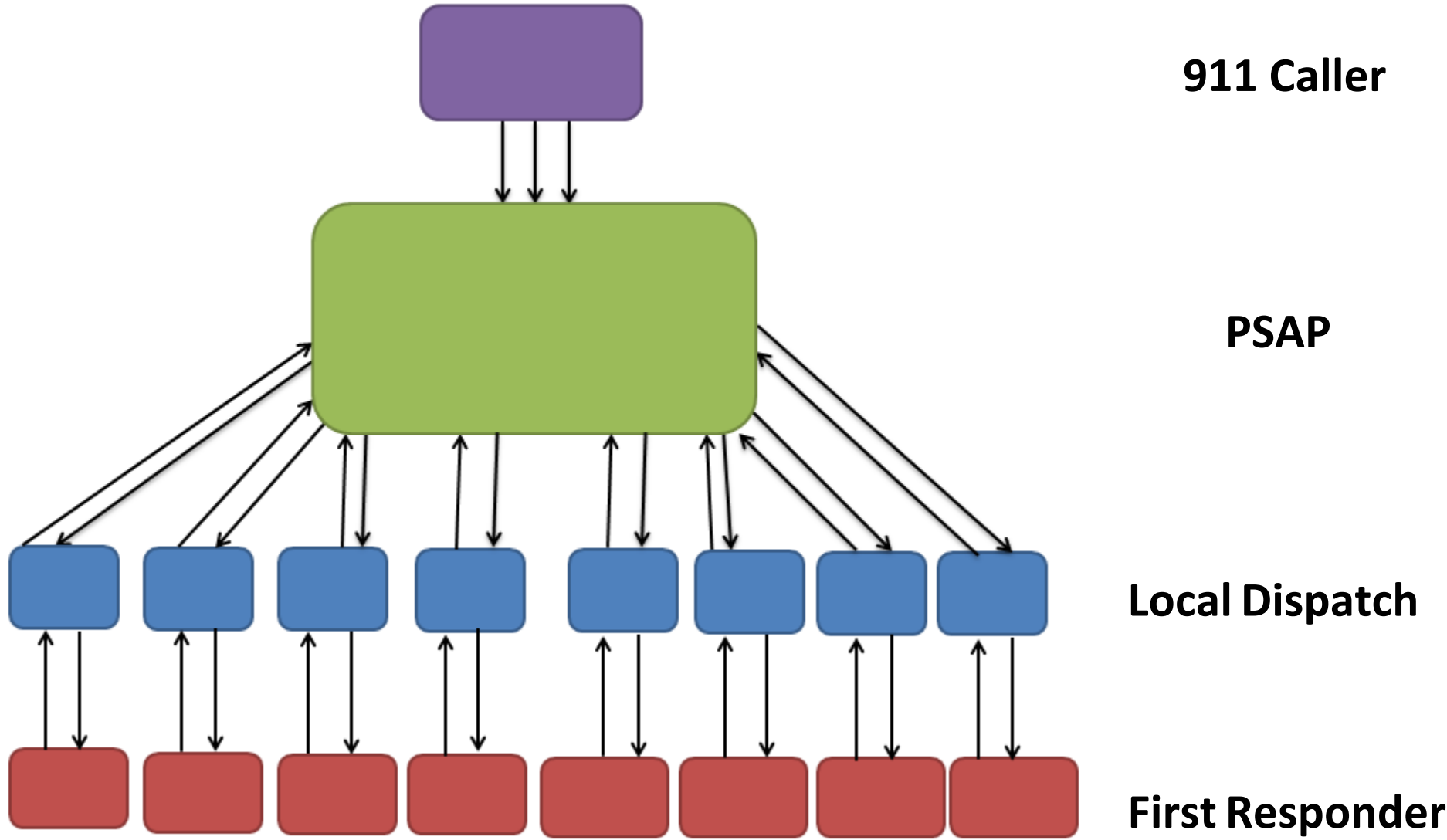
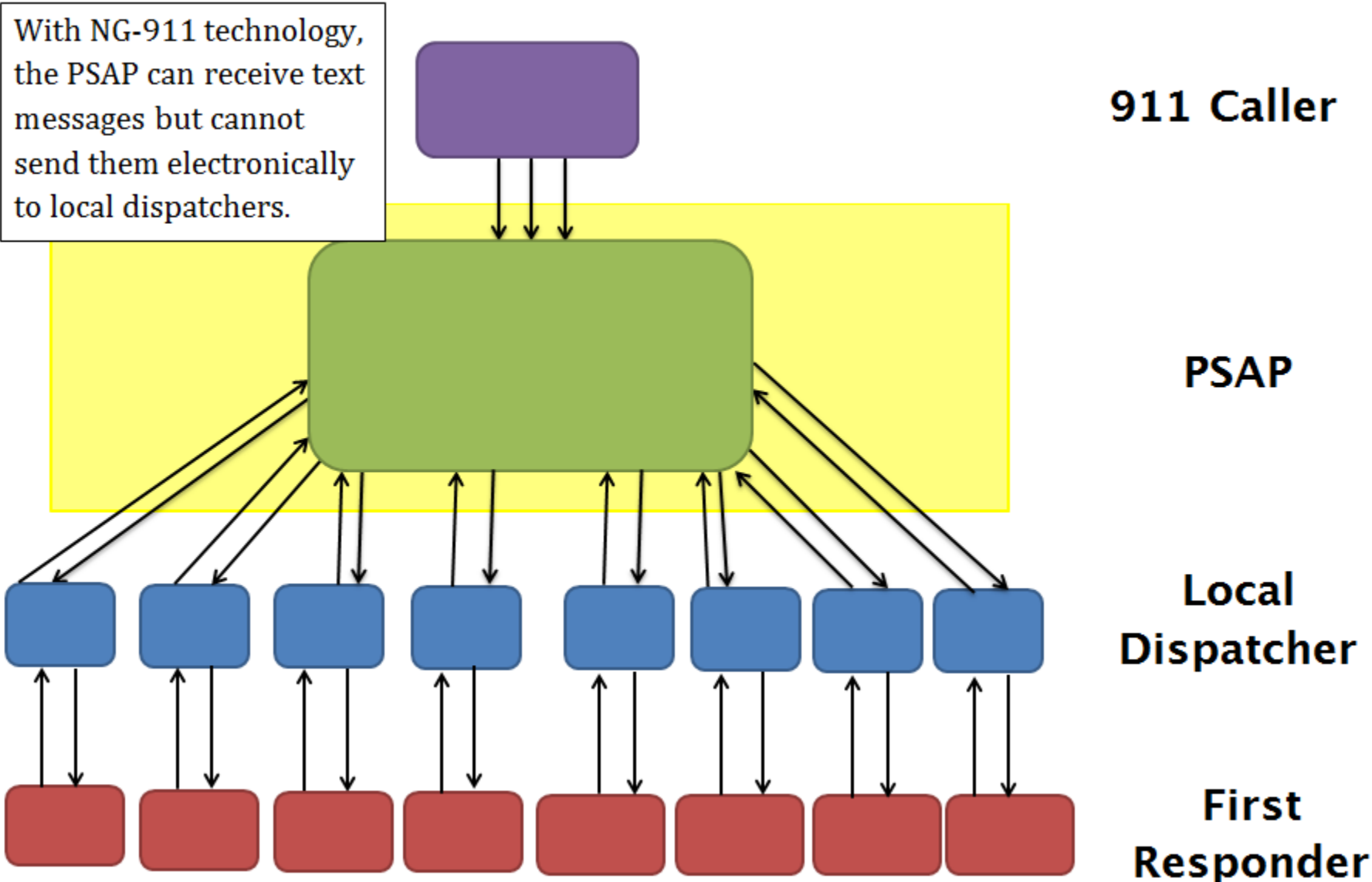

Figure 2: Plan for NG-911 Implementation



Impact of NG-911

Drastic change to the flow of information

- Text or call RI 911
- All calls and texts received by PSAP
- Telecommunicators must interpret text messages and verbally relay info to dispatchers
- Similar to how wireless phones changed 911
- 911 technology will continue to evolve

The State must take necessary steps to:

- Maintain the highest level of public safety
- Mitigate NG-911 State and municipal costs

Challenges of NG-911 Implementation Plan

Interpretation of text messages:

- Only telecommunicators can receive and interpret text messages
- Texts may be hard to interpret due to shorthand or ambiguous language
- Only telecommunicators can send texts back and forth with 911 user for clarification, dispatchers cannot

NG-911 Technology at Local Dispatch Centers

- Installing NG-911 technology at local dispatch centers is necessary to alleviate the challenges that arise when only the PSAP has NG-911 technology

Figure 3: NG-911 Technology at Local Dispatch Centers

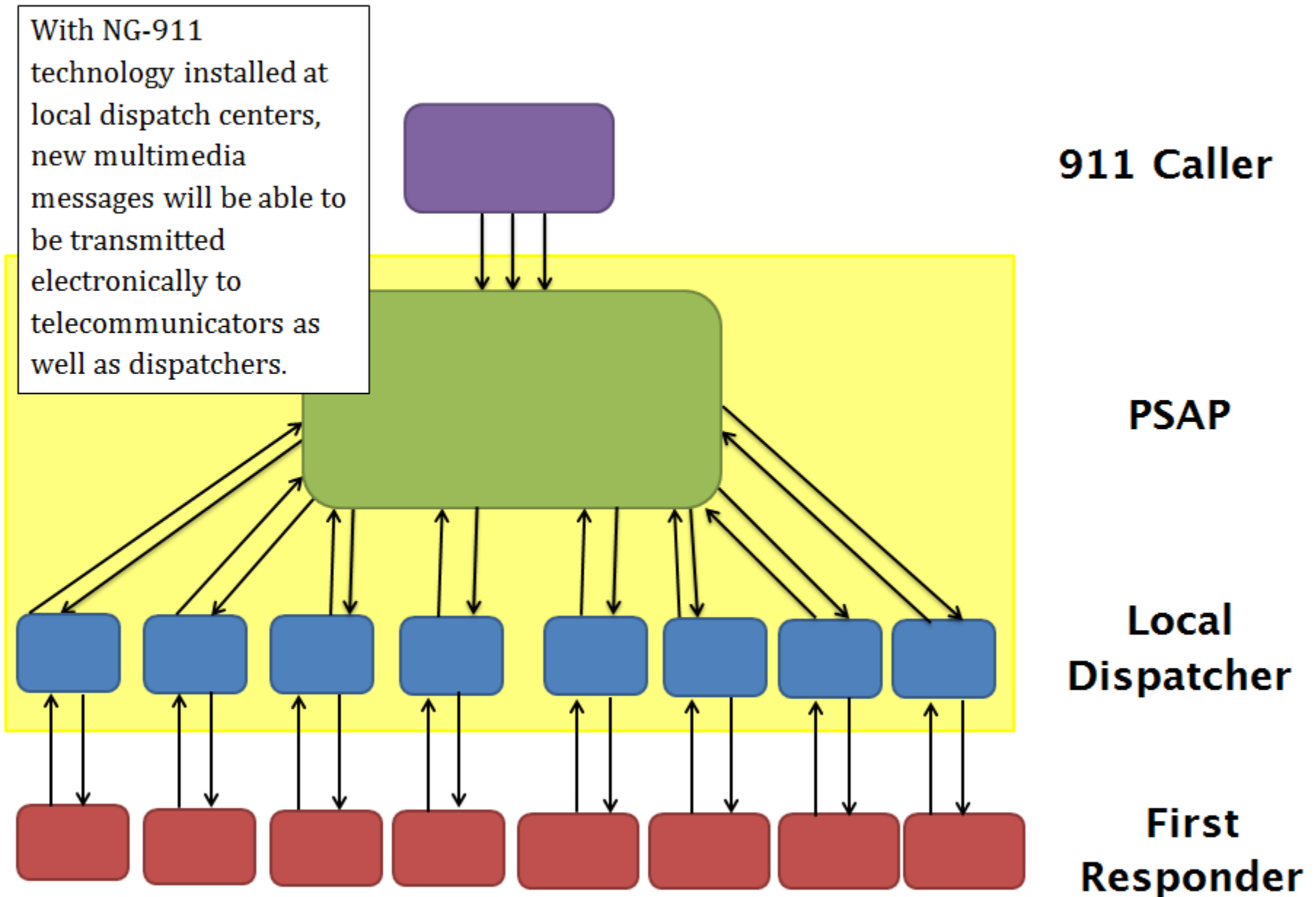

Benefits of NG-911 at Local Level

- Reduces NG-911 strain on telecommunicators
- Reduces communication errors and delays between the PSAP and local dispatchers
- Reversing the information flow is a vastly expedited process

Challenges of Implementation at Local Level

- Municipal costs of implementation and upgrades at 72 municipal dispatch centers:
 - Includes router, static IP broadband connection, and a CAD system interoperable with the PSAP
 - Future costs of system maintenance and upgrades for new technology
- Local dispatch centers with different NG-911 technology will not be interoperable

Alternative Structures to Enhance Public Safety and Mitigate Costs

We evaluate system performance of two different options tailored specifically to Rhode Island:

- Horizontal Consolidation
- Vertical Consolidation

Horizontal Consolidation

- Combines municipal dispatch services by criteria such as region, cooperative agreements, or financial considerations
- For example, multiple municipalities may choose to combine their fire dispatch units into a single dispatch facility
- Would allow municipalities to share the costs of NG-911 implementation

Figure 1: Current 911 System

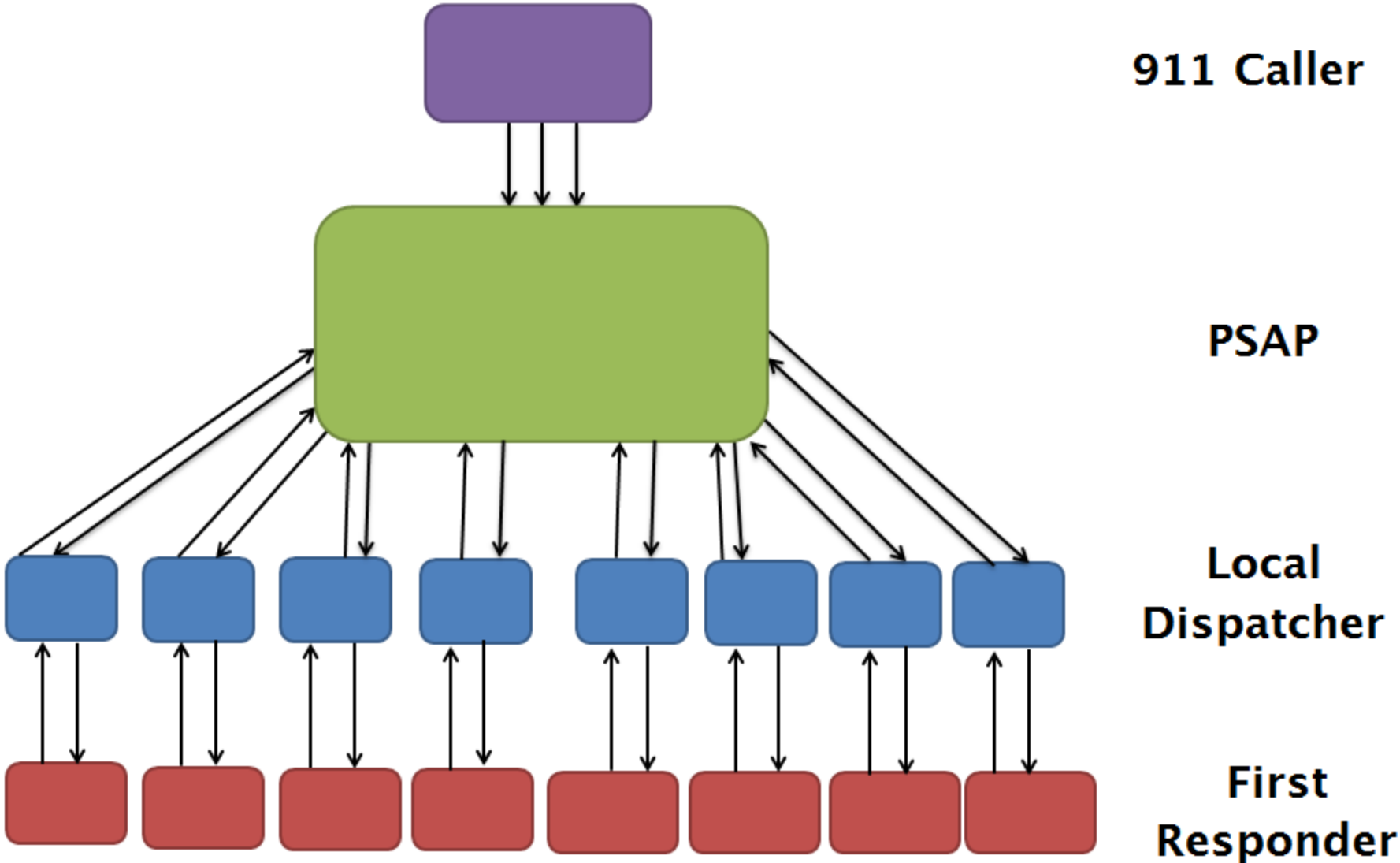
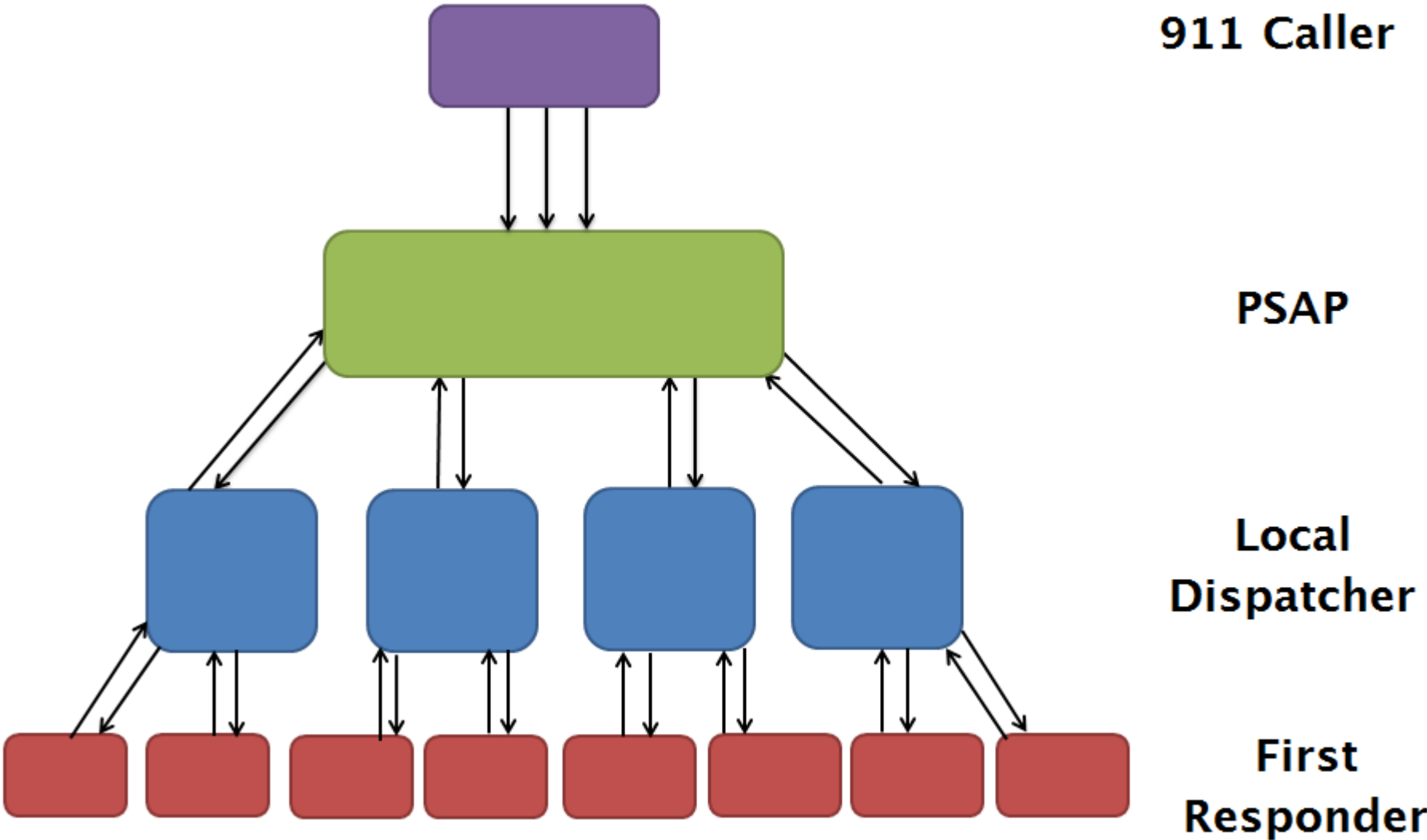

Figure 4: Horizontal Consolidation with NG-911 Implemented



Horizontal Consolidation: Public Safety Implications

Effectiveness of 911 System

- Public safety will neither increase nor decrease

Interoperability Benefits

- Increased interoperability between local dispatch centers if they transition to NG-911 using the same technology

Horizontal Consolidation: Fiscal Implications

Cost Savings

- Fewer local dispatch centers, which would reduce local costs by sharing NG-911 expenses across multiple municipalities

Additional Outlays

- Additional upfront costs for some expanded facilities to house local dispatch centers

Vertical Consolidation

- Create regional facilities, each of which combines PSAP and dispatch responsibilities
- Telecommunicators answer 911 calls and then dispatch emergency services directly

Figure 1: Current 911 System

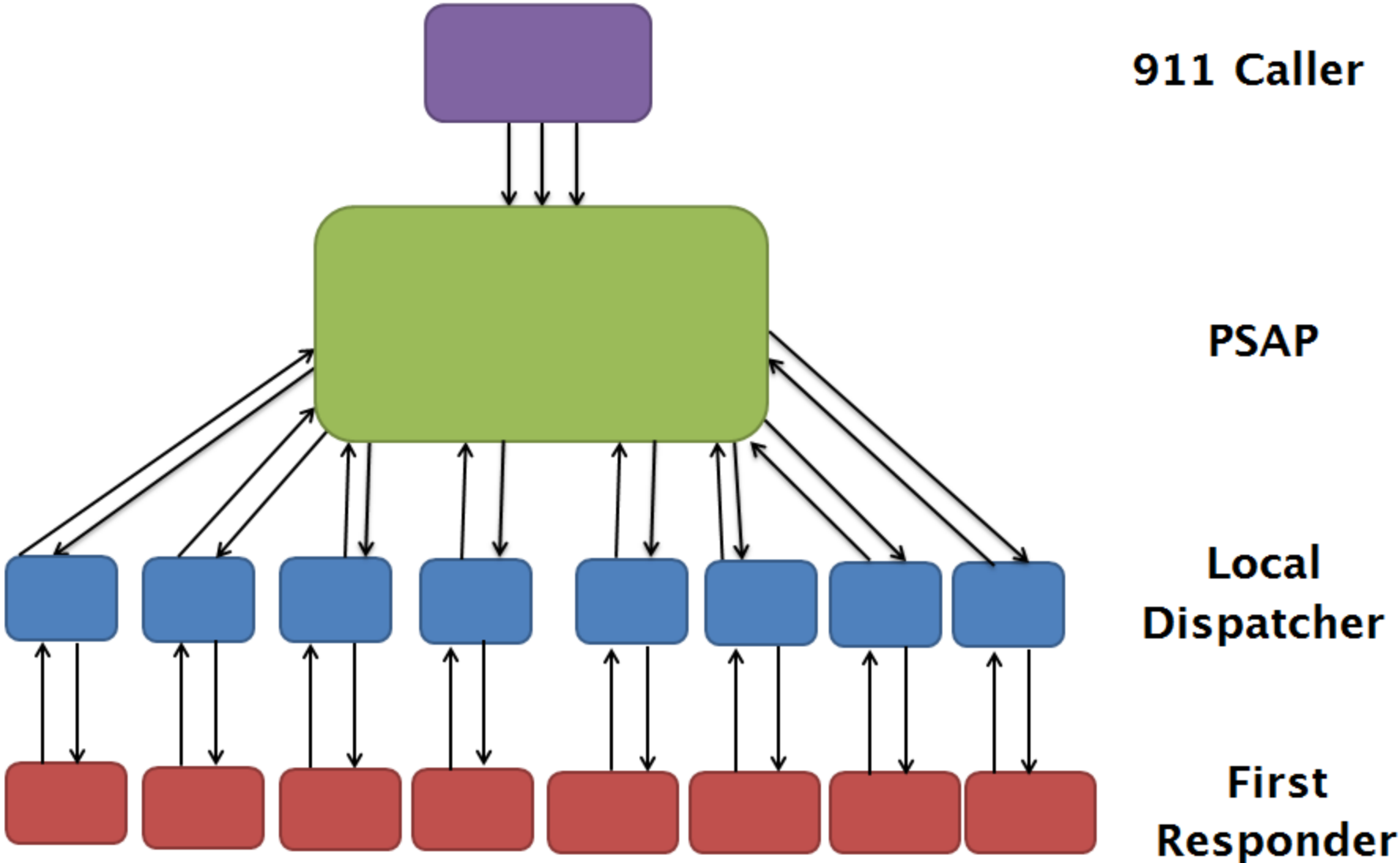
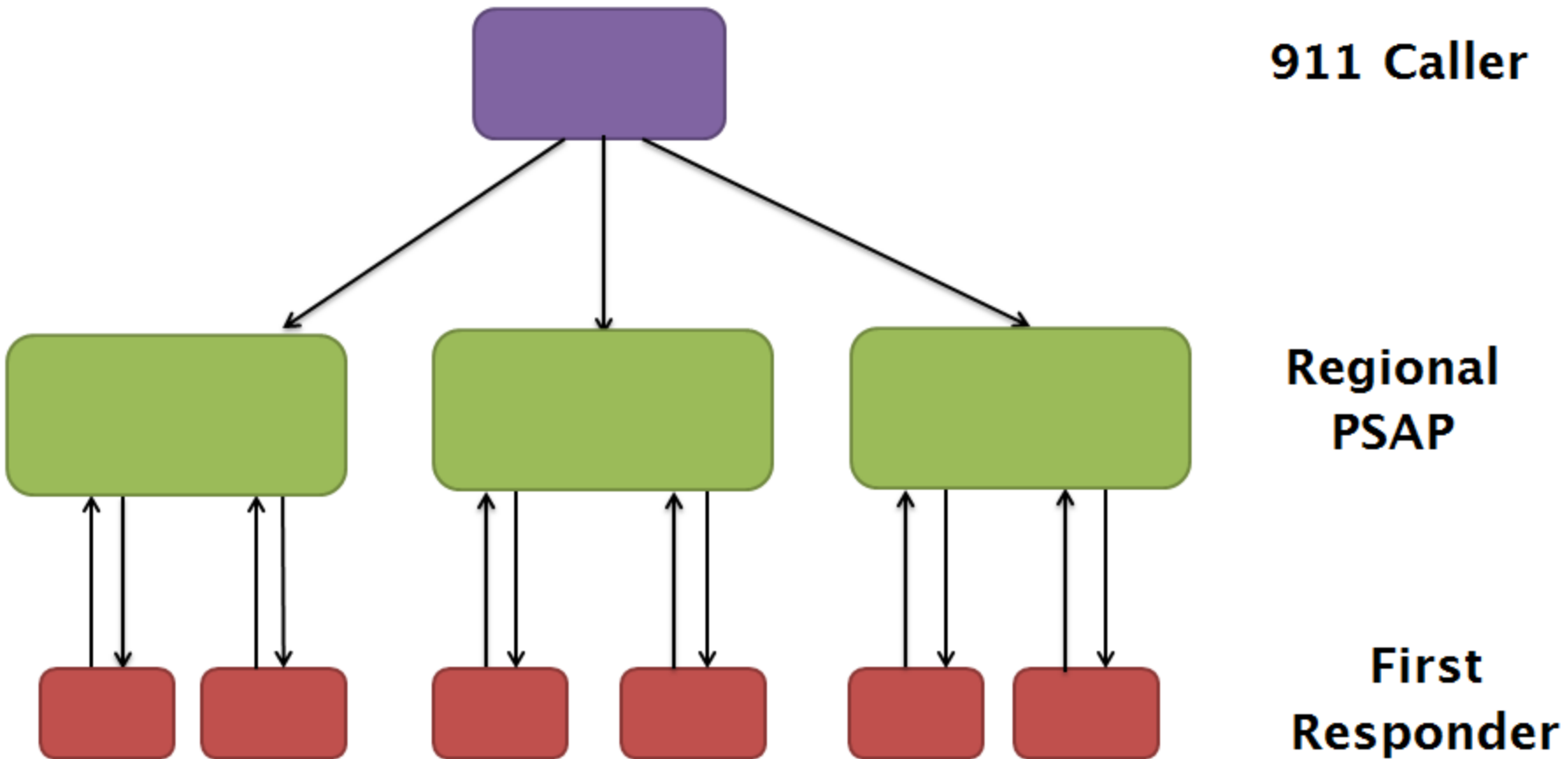

Figure 5: Vertical Consolidation



Vertical Consolidation: Public Safety Implications

Improves public safety by removing a point of contact in the four-point transmission chain:

- Decreasing transmission error
- Increases speed of response

Issues

- Reduction of local knowledge in dispatch

Vertical Consolidation: Fiscal Implications

Cost Savings

- Reducing the number of facilities requiring upgrades will reduce long term costs
- Combining dispatch and PSAP responsibilities into single facilities will remove a link in the 911 transmission chain

Additional Outlays

- Capital and infrastructure costs associated with building new PSAPs or upgrading current facilities to serve this role

Recommendation

Move forward with horizontal consolidation:

- Reduces costs
- Maintains public safety
- Does not preclude moving to vertical consolidation

State actions:

- Regulate NG-911 technology and protocols at the dispatch level
- Explore cost-sharing programs to mitigate up-front capital costs to municipalities during consolidation

Need for Pilot Projects

Multiple pilot projects, each one combining 3–5 municipalities

Criteria:

- Geography (urban, suburban, rural)
- Population (tourists, linguistics, density)
- Call volume
- Existing ties between municipalities

Thank you